

Pergola

# **PR6000**®

**TECHNICAL SPECIFICATION DOCUMENT**





## TABLE OF CONTENTS:

PR6000-HT Pergola	2
Cross-sections	4
Specification of parts	8
Dimensioning	25
Assembly drawings – pergola with two motors	26
Pergola PR6000-LITE	27
Cross-sections	28
Specification of parts	32
Dimensioning	40

# PR6000<sup>®</sup>



*PR6000 is a trade mark of PORTOS.  
All pictures and drawings included herein are only for illustrative purposes.  
PORTOS reserves the right to make changes. ©2022 PORTOS.  
All rights reserved.*

# PR6000®



## MAP KEY (EXPLANATIONS:



Approximate weight of the part (in kilos)



Maximum length of long elements (in metres)



Material used for the production of the element (e.g. STEEL, PVC, etc.)



Elements with a lining option

# PR6000® system diagram and list of parts Standalone

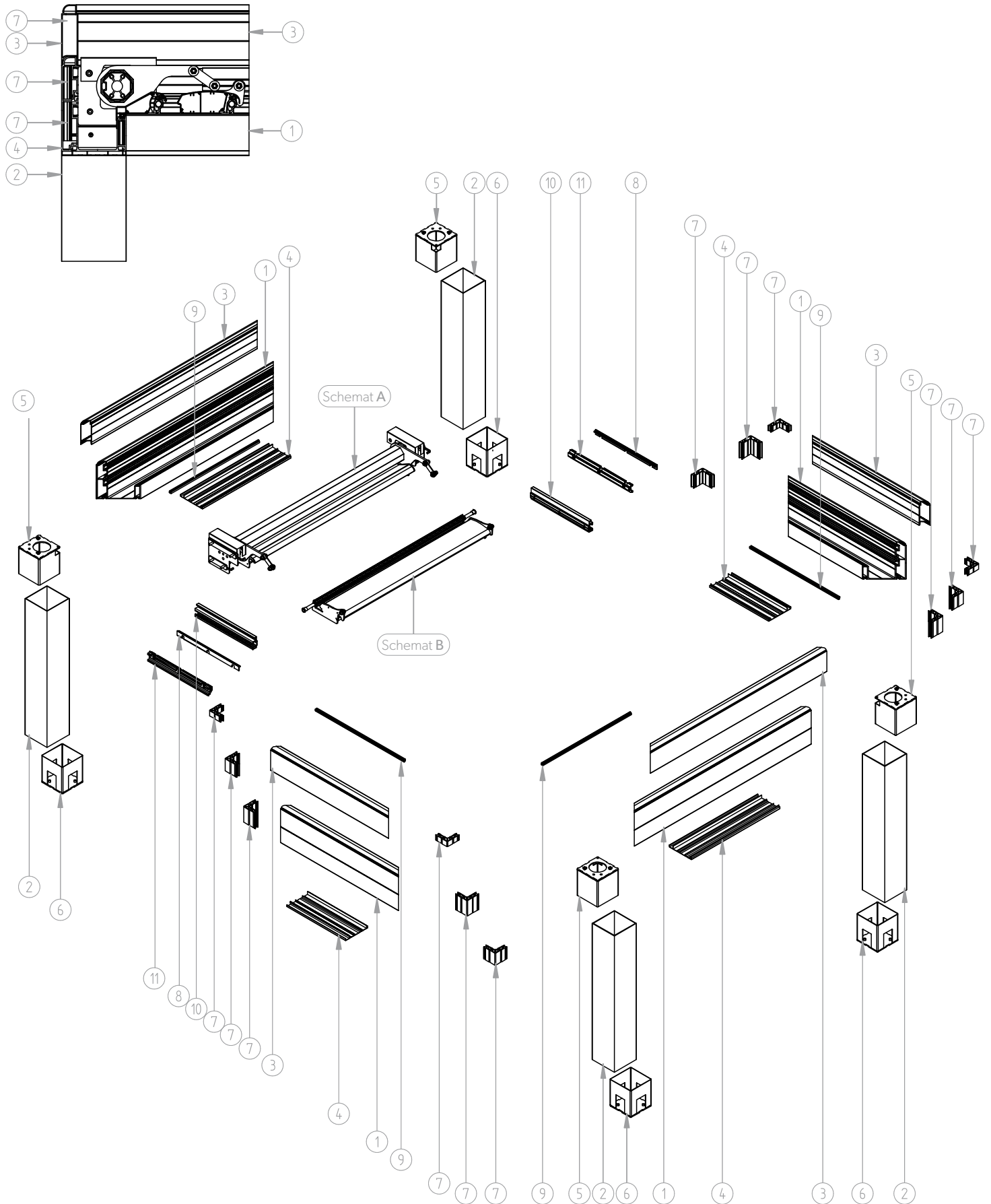

## PR6000<sup>®</sup> Standalone - list of parts

1. PRP-010	Side profile – gutter
2. PRP-040	Load bearing column of pergola
3. PRP-020	Gutter height adjustment profile
4. PRP-160	Gutter bottom masking profile
5. PRT-050	Upper column bracket
6. PRT-060	Bottom column bracket
7. PRP-140	Gutter corner bracket
8. PRP-120	Protective profile for the slats
9. PRU-040	'B' type gutter seal
10. PRP-100	Slat bracket profile
11. PRP-110	Slat fixing profile

# PR6000® system diagram and list of parts Wall Mounted

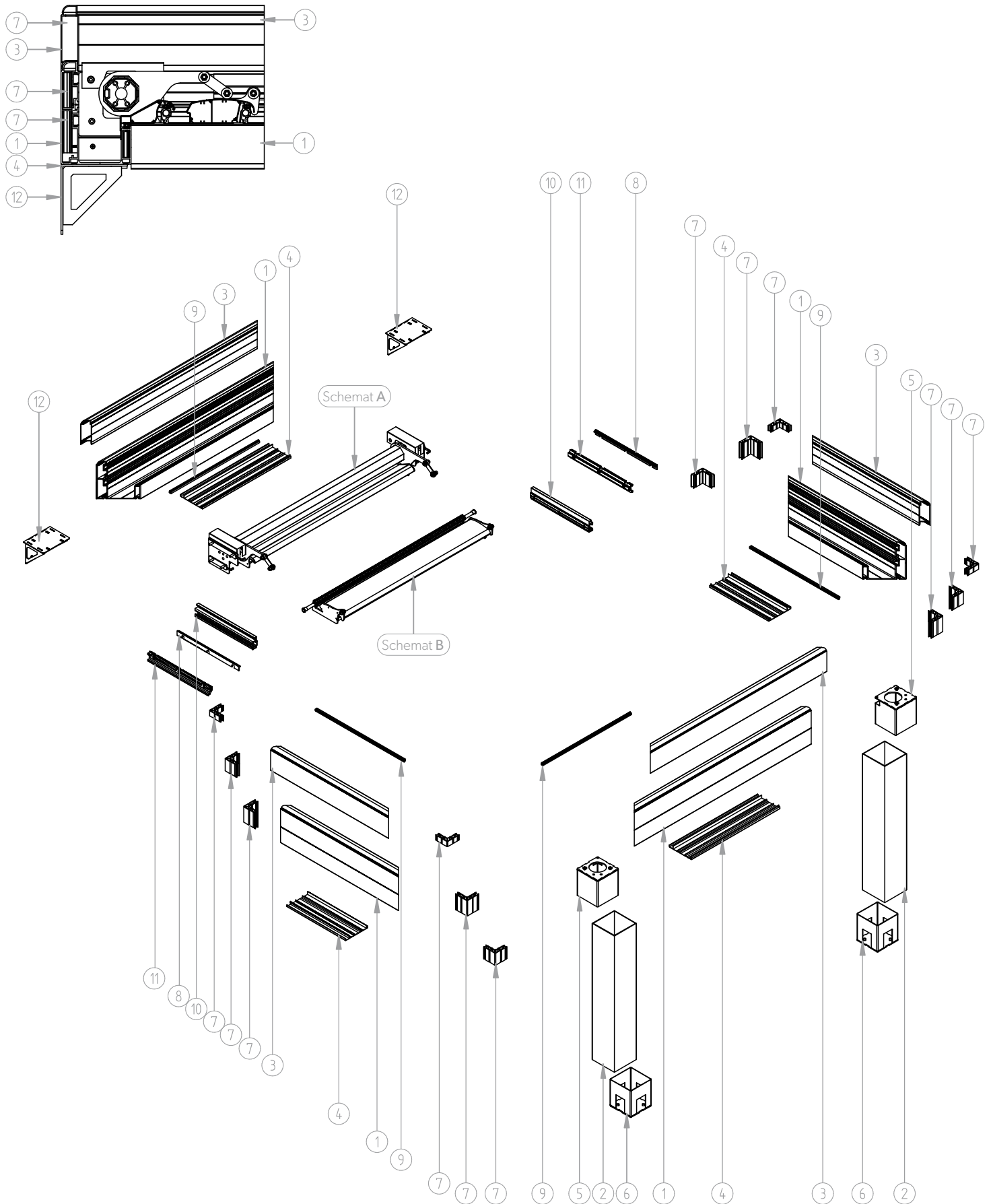

## PR6000<sup>®</sup> Wall Mounted - list of parts

1. PRP-010	Side profile – gutter
2. PRP-040	Load bearing column of pergola
3. PRP-020	Gutter height adjustment profile
4. PRP-160	Gutter bottom masking profile
5. PRT-050	Upper column bracket
6. PRT-060	Bottom column bracket
7. PRP-140	Gutter corner bracket
8. PRP-120	Protective profile for the slats
9. PRU-040	'B' type gutter seal
10. PRP-100	Slat bracket profile
11. PRP-110	Slat fixing profile
12. PRT-161	Wall Mount Bracket

# PR6000® system diagram and list of parts Diagram A

Diagram A - assembly drawing and list of parts of the motor system with the first slat.

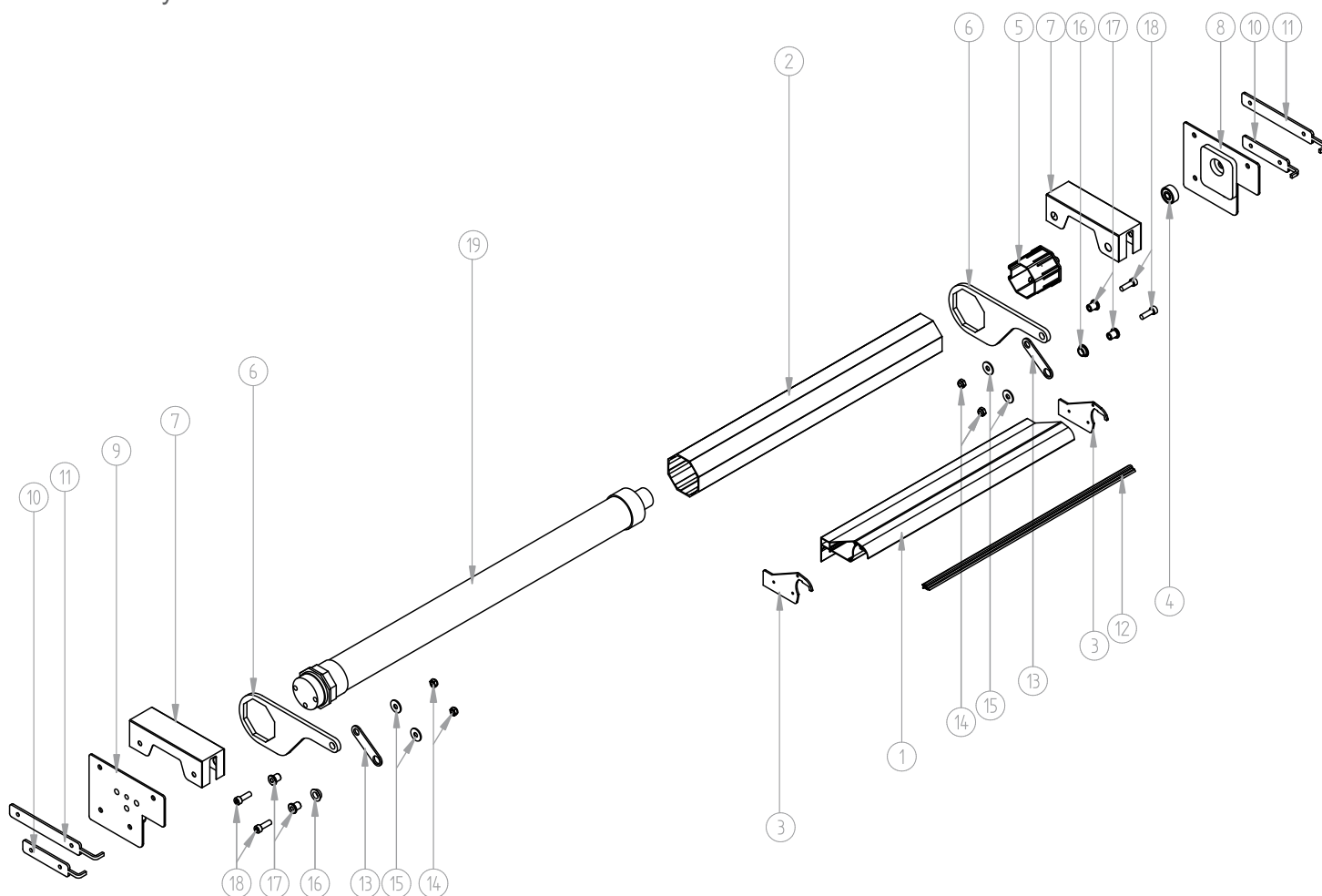

1.	PRP-180	The first fixed roof slat
2.	PRP-060	Octagonal tube
3.	PRT-230	Side end cap of the first fixed roof slat
4.		Ball bearings
5.	PRT-130	Holder ALU 70mm
6.	PRT-240	Slat motor holder
7.	PRT-300	Motor casing for the fixed slat
8.	PRT-290	R/LRight/left gantry plate to fix motor to the fixed slat
9.	PRT-280	R/LRight/left side motor plate for the fixed slat
10.	PRT-260	Small nut of the motor plate bracket – for the slats
11.	PRT-270	Large nut of the motor plate bracket – for the slats
12.	PRU-020	'A' type slat seal
13.	PRT-250	Slat motor bracket
14.	M8 NUT	M8 Self-locking Counter Nut
15.	23 WASHER	FI 8 WASHER
16.	PRD-070	Sliding sleeve 12 mm
17.	PRT-180	Threaded sleeve
18.	M8x25 SCREW	M8x25 Hex socket head screw
19.		Motor

Diagram B - assembly drawing and list of parts of other slats.

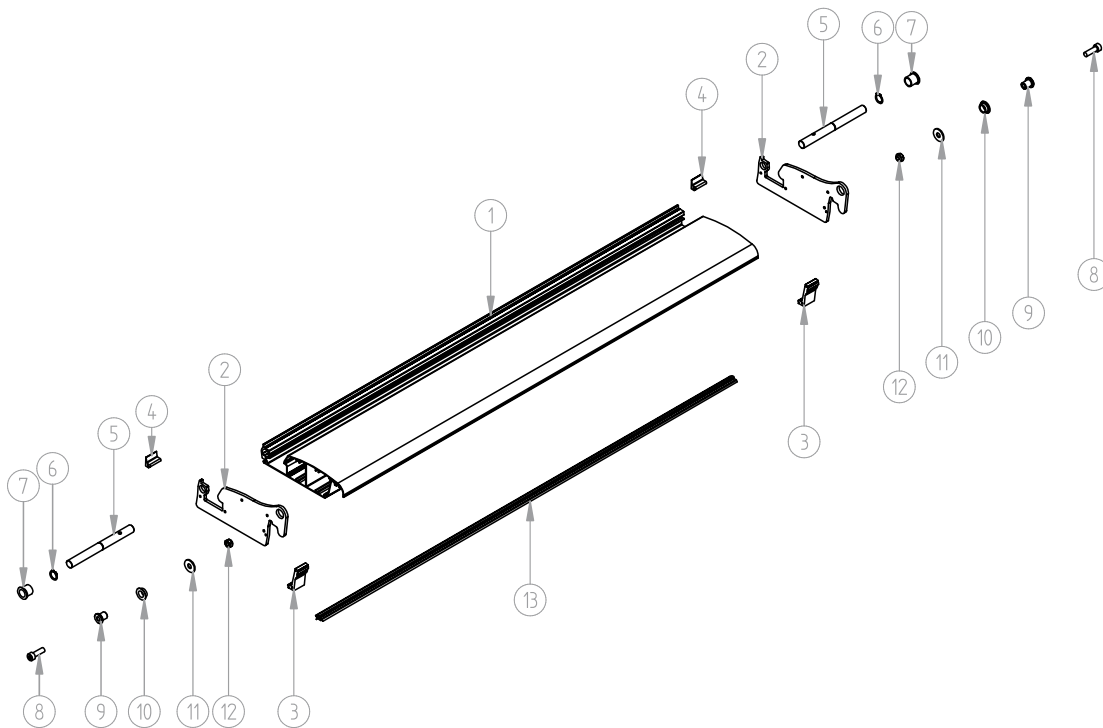

1.	PRP-080	Roof slat
2.	PRT-020	Side end cap of the roof slat
3.	PRD-020	Roof slat seal – large
4.	PRD-010	Roof slat seal – small
5.	PRT-150	Mandrel of the slats
6.		External stop collar Fi 14
7.	PRD-060	Sliding sleeve 14 mm
8.	ŚRUBA M8x25	M8x25 Hex socket head screw
9.	PRT-180	Threaded sleeve
10.	PRD-070	Sliding sleeve 12 mm
11.	PODKŁADKA 23	FI 8 WASHER
12.	NAKRETKA M8	M8 Self-locking Counter Nut
13.	PRU-020	'A' type slat seal

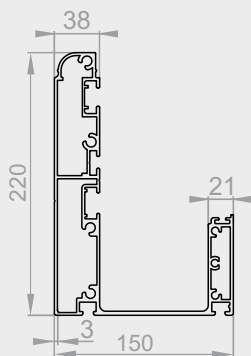
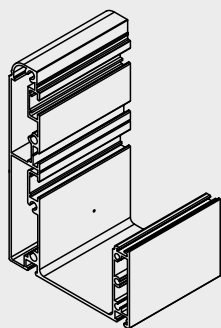

### PRP-010

Side profile – gutter.

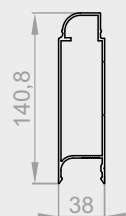
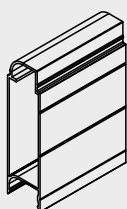

### PRP-020

Gutter height adjustment profile.

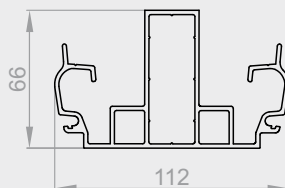
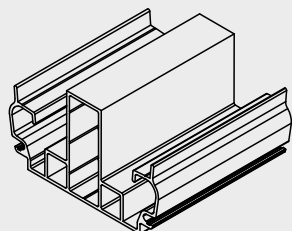

### PRP-030

Roof bar.

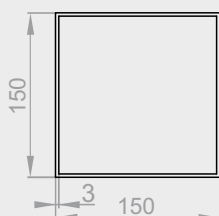
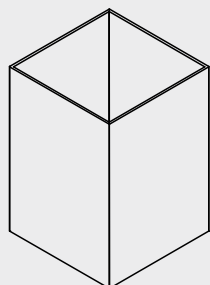

### PRP-040

Load bearing column of pergola.



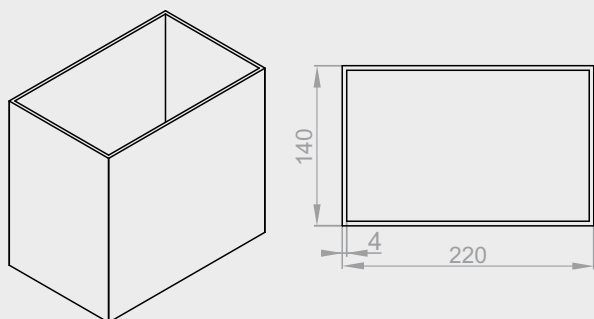

### PRP-050

Double load bearing column of pergola.

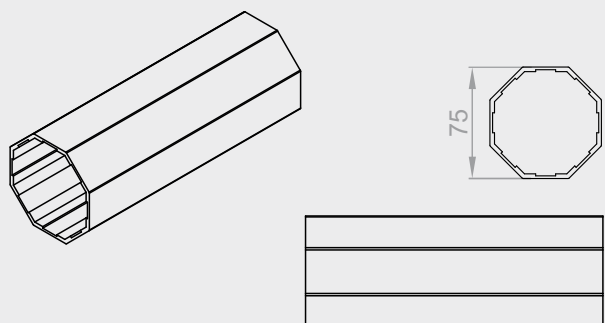

### PRP-060

Octagonal tube.

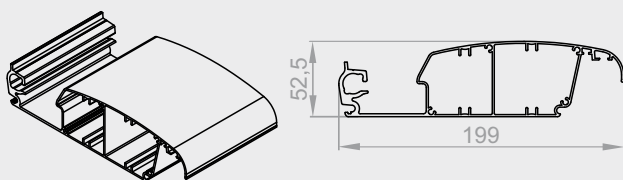

### PRP-080

Roof slat.

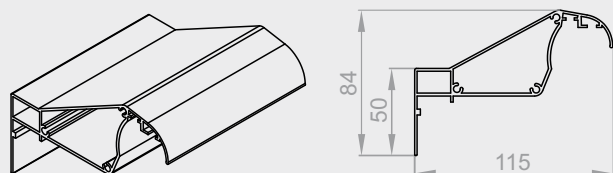

### PRP-180

The first fixed roof slat.



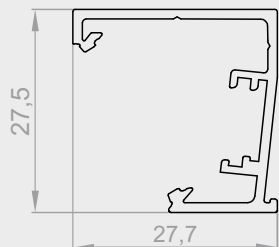
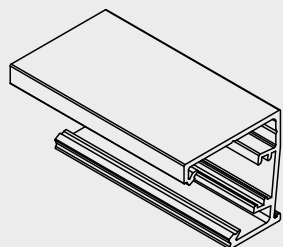

### **PRP-130**

LED lighting profile.

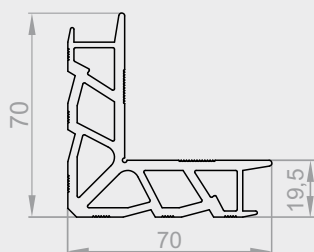
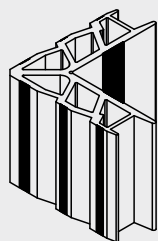
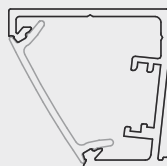

### **PRP-140**

Gutter corner bracket.

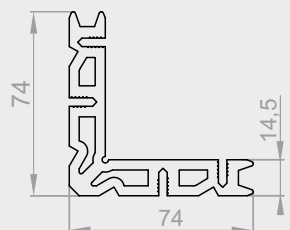
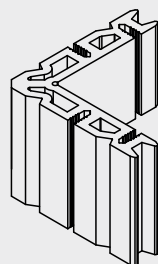

### **PRP-150**

Internal gutter corner bracket.

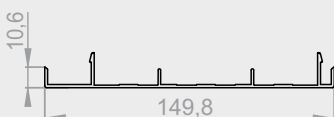
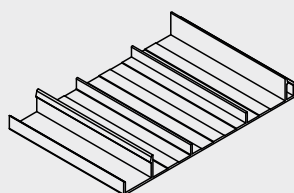

### **PRP-160**

Gutter bottom masking profile.



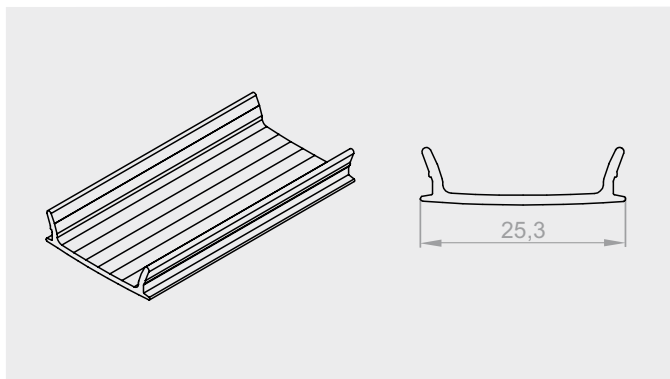

**PRP-200**

Casing of LED lighting profile.

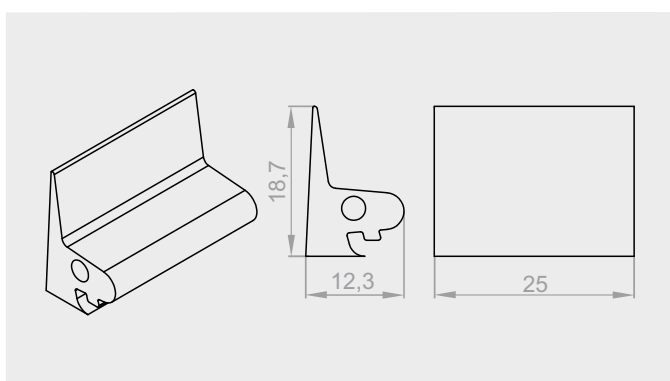
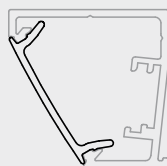

**PRD-010**

Roof slat seal.

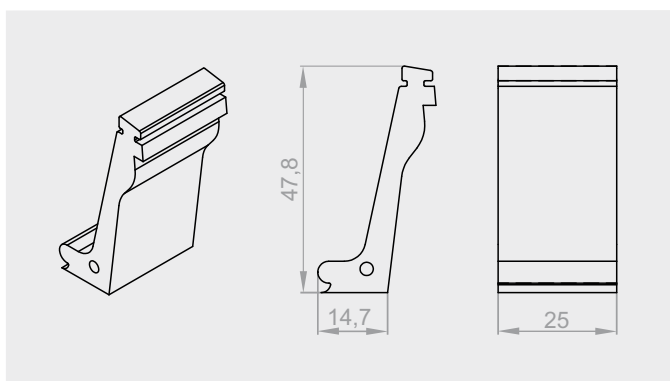

**PRD-020**

Large roof slat seal.

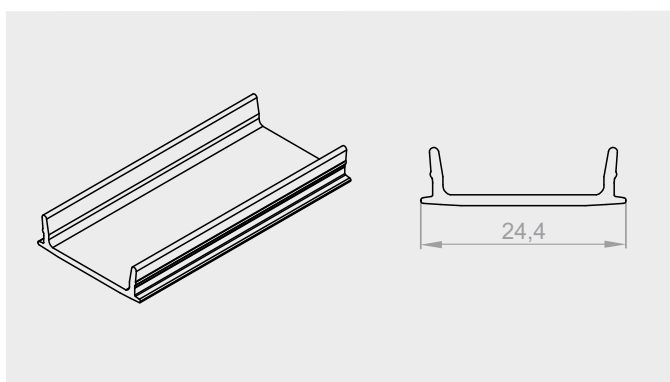

**PRD-030**

Casing of LED lighting.

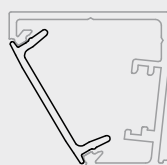

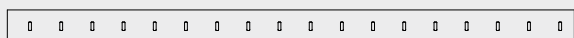

**PRE-050**

LED lighting profile.

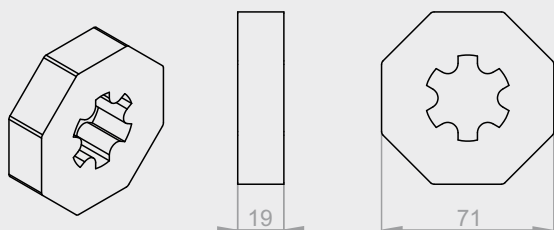

**PRD-040**

Drive 70 mm.

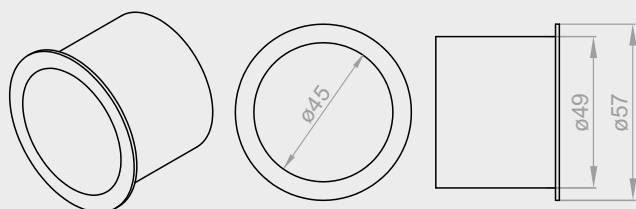

**PRD-050**

Water discharge sleeve.

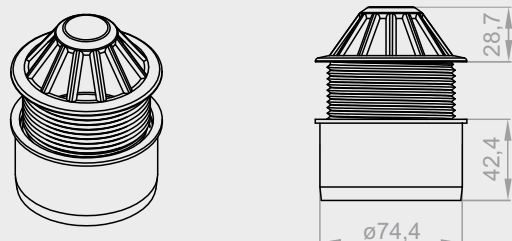

**PRD-051**

Water discharge sleeve.



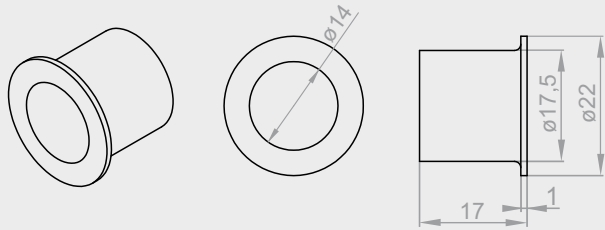

**PRD-060**

Sliding sleeve 14 mm.

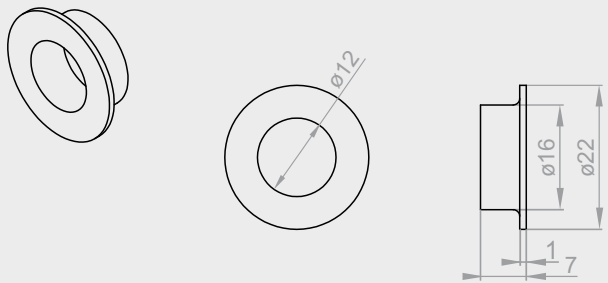

**PRD-070**

Sliding sleeve 12 mm.

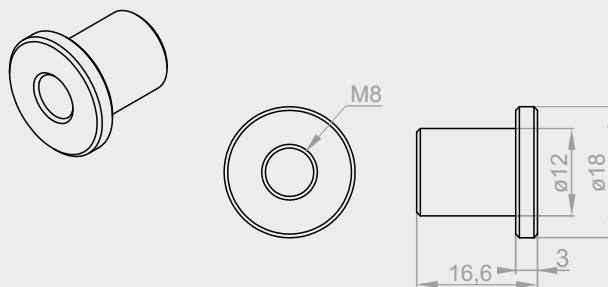

**PRT-180**

Threaded sleeve.

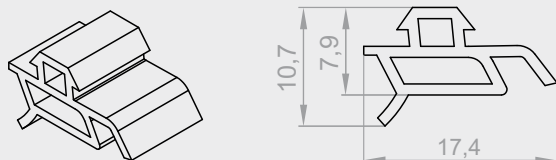

**PRU-020**

'A' type slat seal.



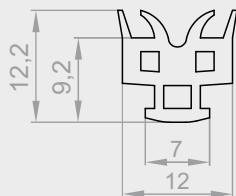
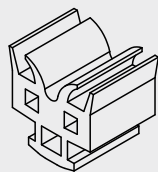

### **PRU-040**

'B' type gutter seal.

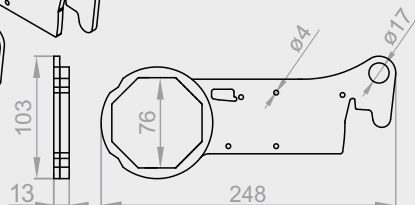
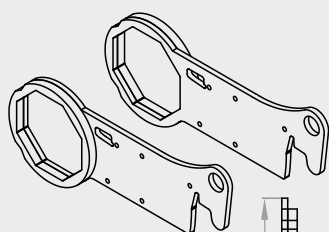

### **PRT-010 P/L**

Right/left side end cap of the first roof slat.

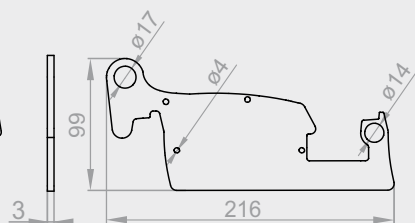
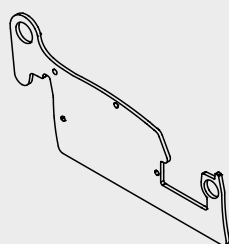

### **PRT-020**

Side end cap of the roof slat.

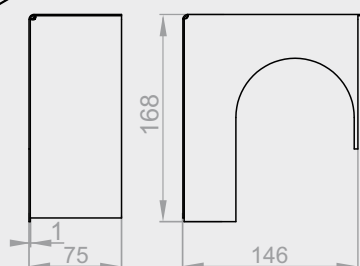
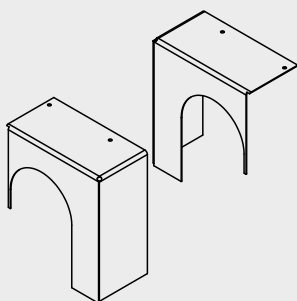

### **PRT-030 P/L**

Right/left motor cover.



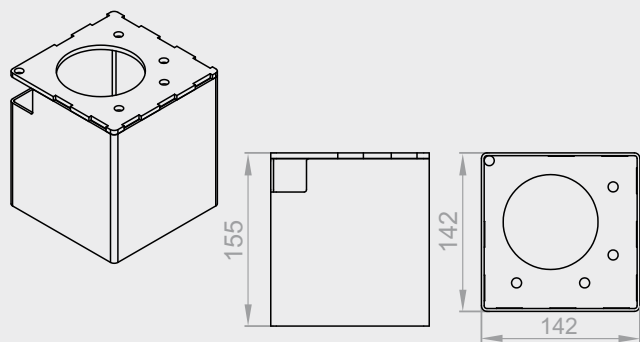

**PRT-050**

Upper column bracket.

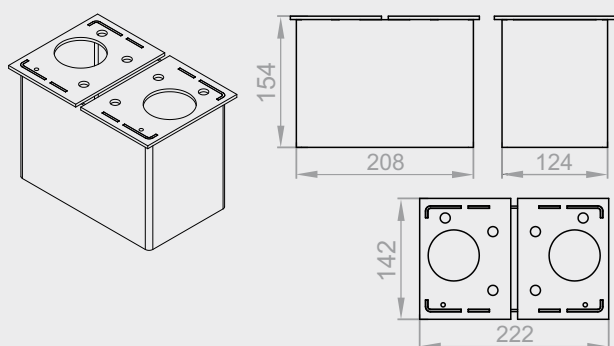

**PRT-320**

Double upper column bracket.

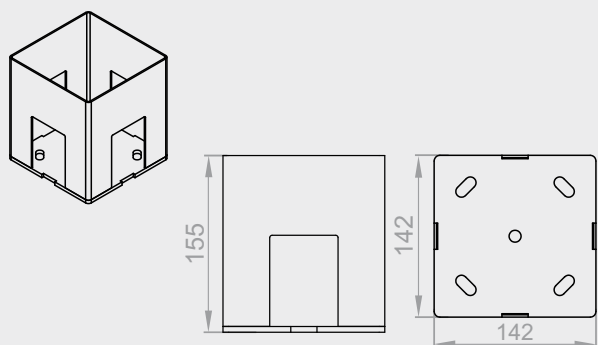

**PRT-060**

Bottom column bracket.

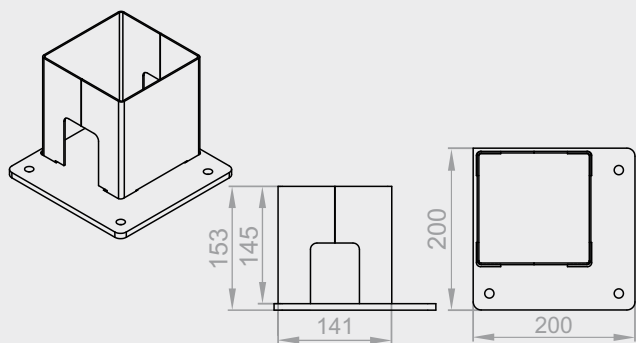

**PRT-190**

Bottom column bracket with a gantry plate.



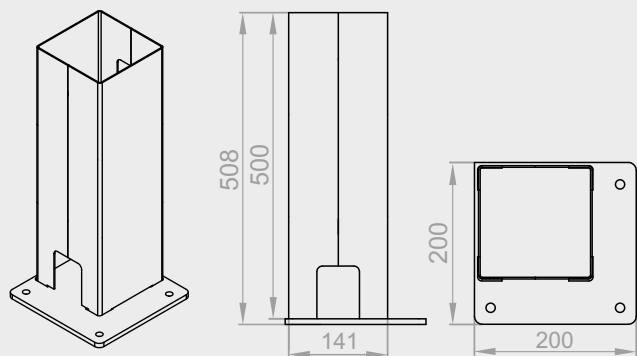

### **PRT-210**

High bottom column bracket with a gantry plate.

STEEL

1pc  
8,10kg

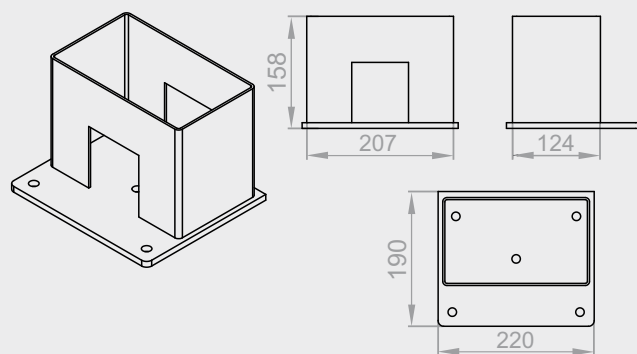

### **PRT-310**

Double bottom column bracket.

STEEL

1pc  
4,53kg

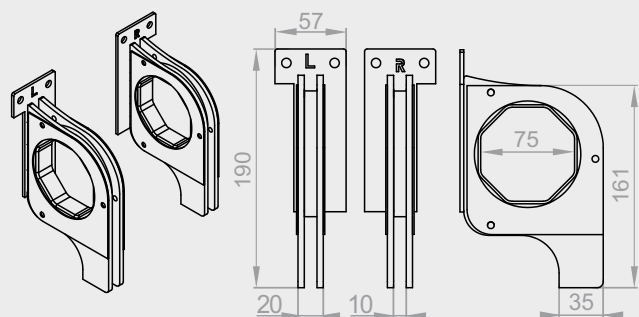

### **PTRK-010 P/L**

Right/left safety chuck for the octagonal tube.

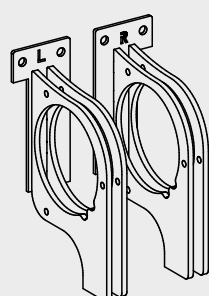

### **PRT-040 L+P**

Octagonal tube mounting bracket.



### **PRT-070**

Octagonal tube bearings.



### **PRT-080**

Octagonal ring.

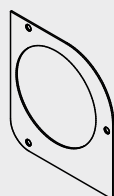

### **PRT-170 - 2 pieces for the set**

Side metal sheet of the octagonal tube mounting bracket.

View of folded safety chuck for the octagonal tube **PTRK-010**:

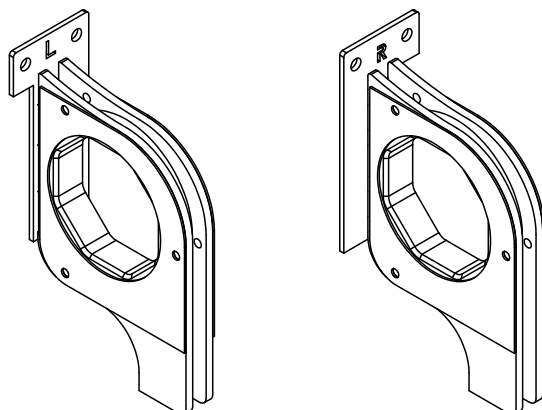

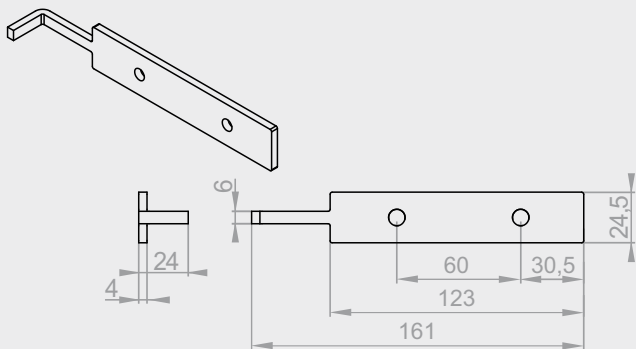

### PRT-090

Nut of the motor plate bracket.

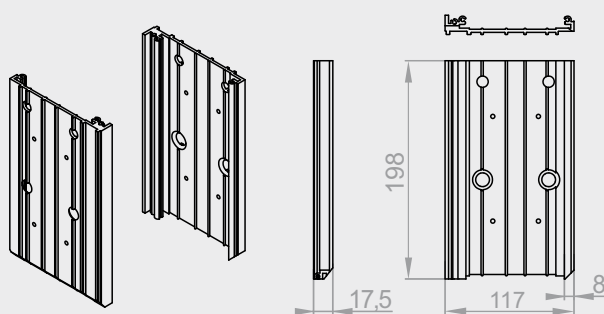

### PRT-100 P/L

Right/left motor plate bracket.

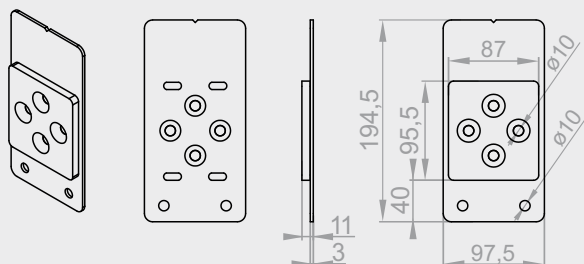

### PRT-110

Motor gantry plate.

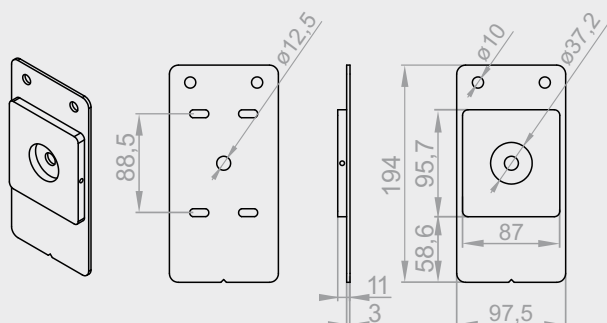

### PRT-120

Side motor plate.



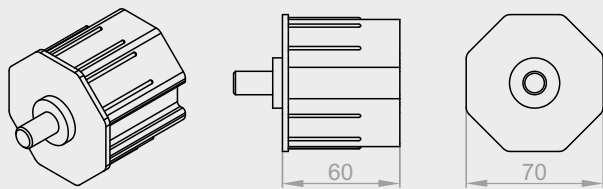

**PRT-130**

Holder ALU 70mm.

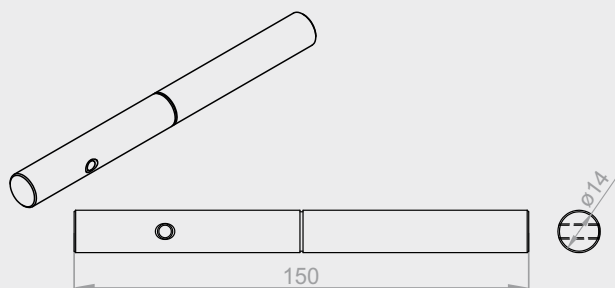

**PRT-150**

Mandrel of the slats.

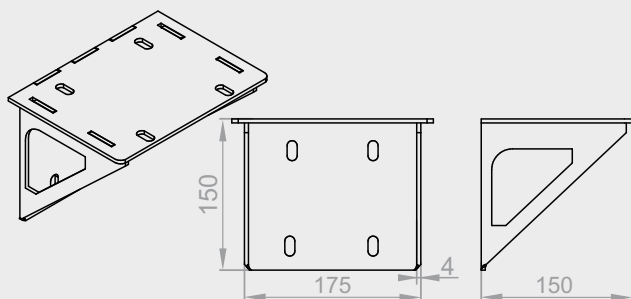

**PRT-161**

Wall mount bracket.

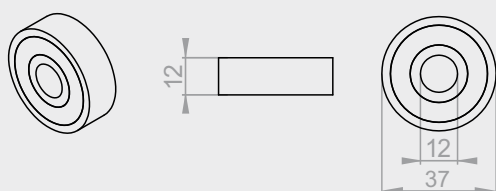

**PRT-200**

Ball bearings 6301 ZZ 12x37x12.

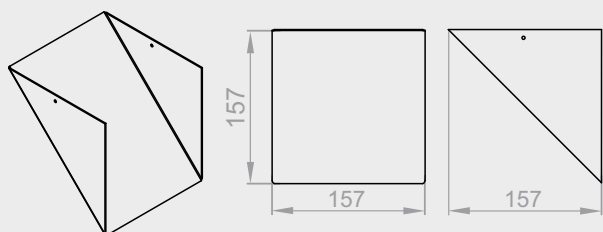

**PRT-220**

Wall mount bracket cover.



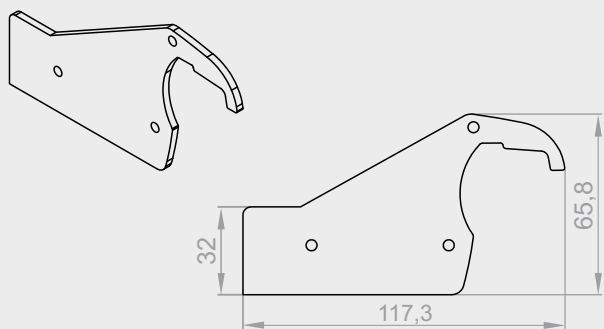

### **PRT-230**

Side end cap of the first fixed roof slat.

STEEL

1pc  
0,1kg

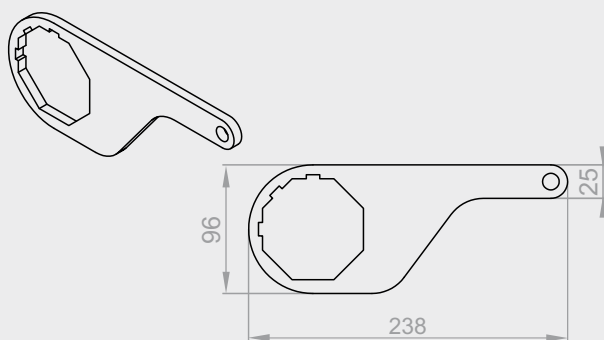

### **PRT-240**

Slat motor holder.

STEEL

1pc  
0,59kg

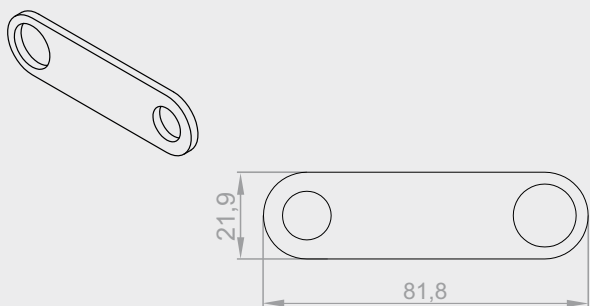

### **PRT-250**

Slat motor bracket.

STEEL

1pc  
0,03kg

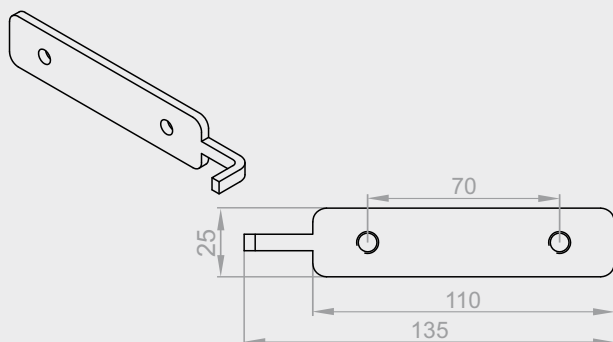

### **PRT-260**

Small nut of the motor plate bracket - for the slats.

STEEL

1pc  
0,09kg

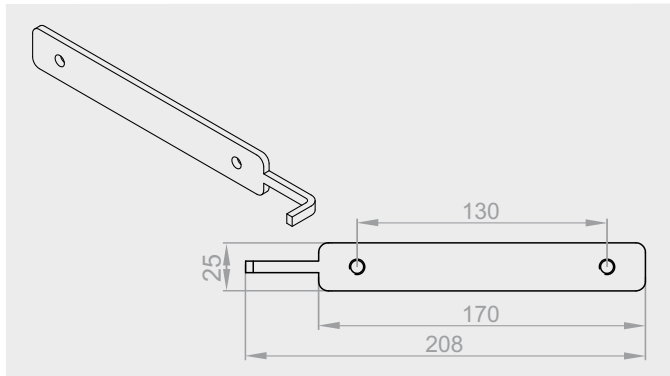

### **PRT-270**

Large nut of the motor plate bracket – for the fixed slat.

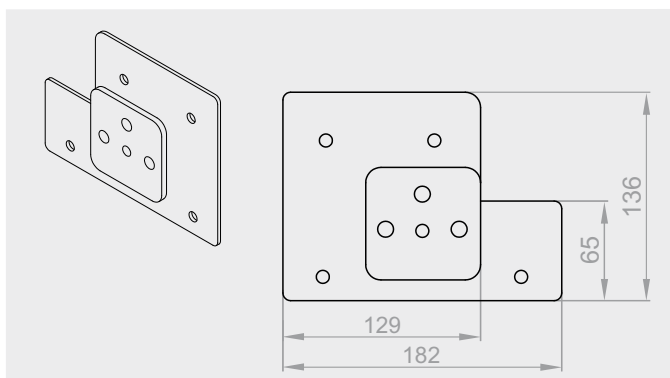

### **PRT-280 P/L**

Right/left side motor plate for the fixed slat.

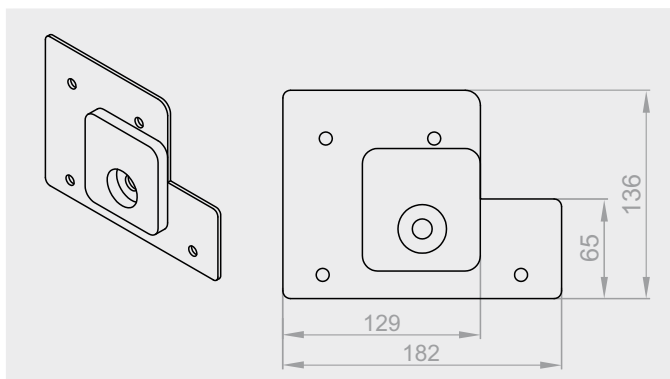

### **PRT-290 P/L**

Right/left gantry plate to fix the motor to the fixed slat.

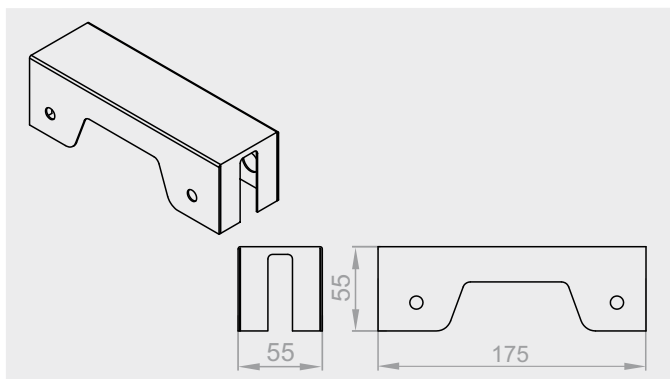

### **PRT-300**

Motor casing for the fixed slat.



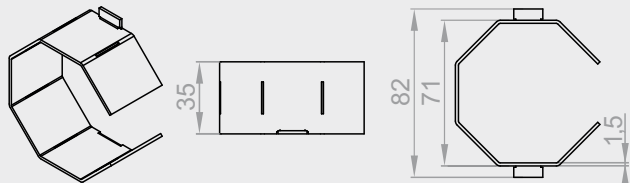

### **PRT-140**

Octagonal motor adapter.

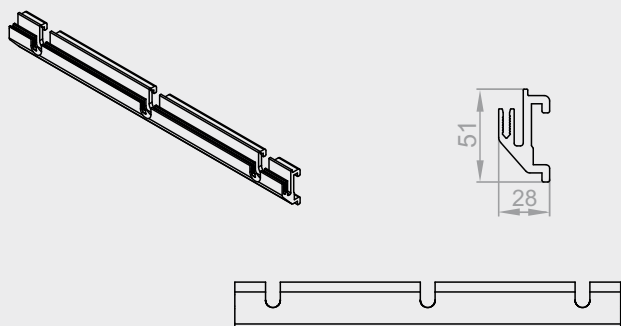

### **PRP-110**

Slat fixing profil.

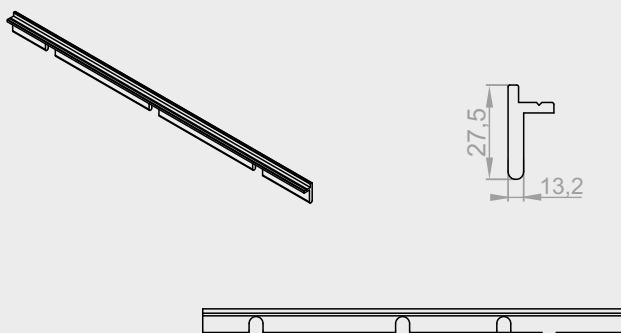

### **PRP-120**

Protective profile for the slats.

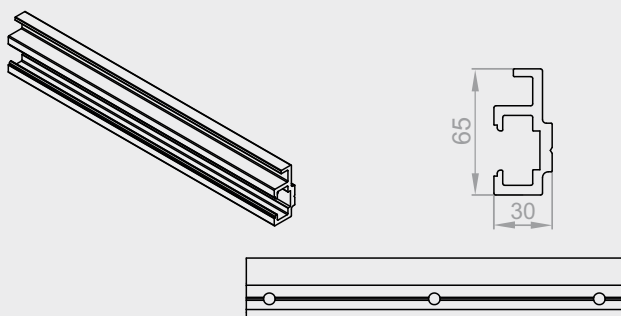

### **PRP-100**

Slat bracket profile.



Dimensioning of PR6000 pergola

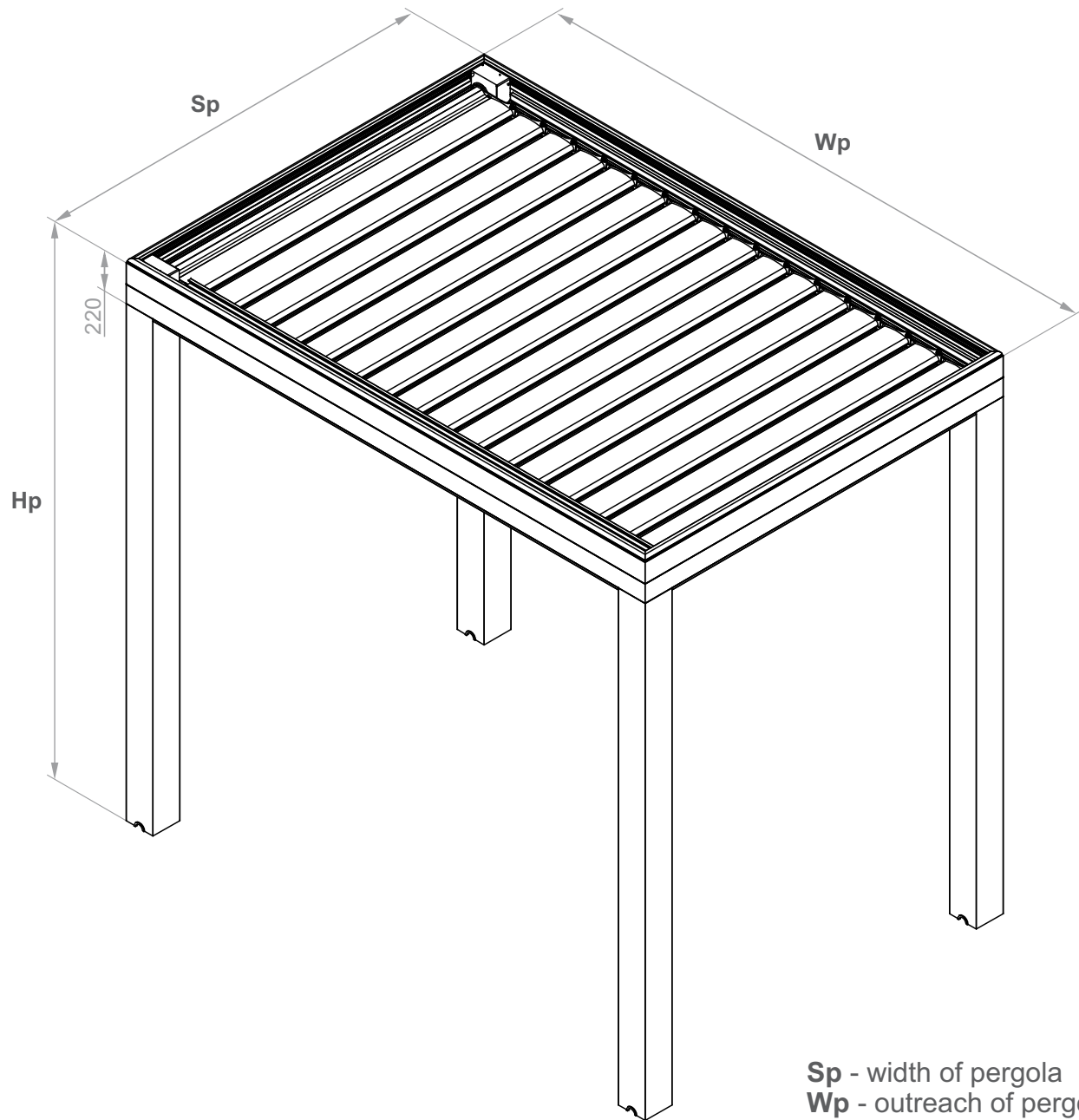

**Sp** - width of pergola  
**Wp** - outreach of pergola  
**Hp** - height of pergola

# PR6000® Pergola Pergola with two motors

Cross-section of pergola with two motors

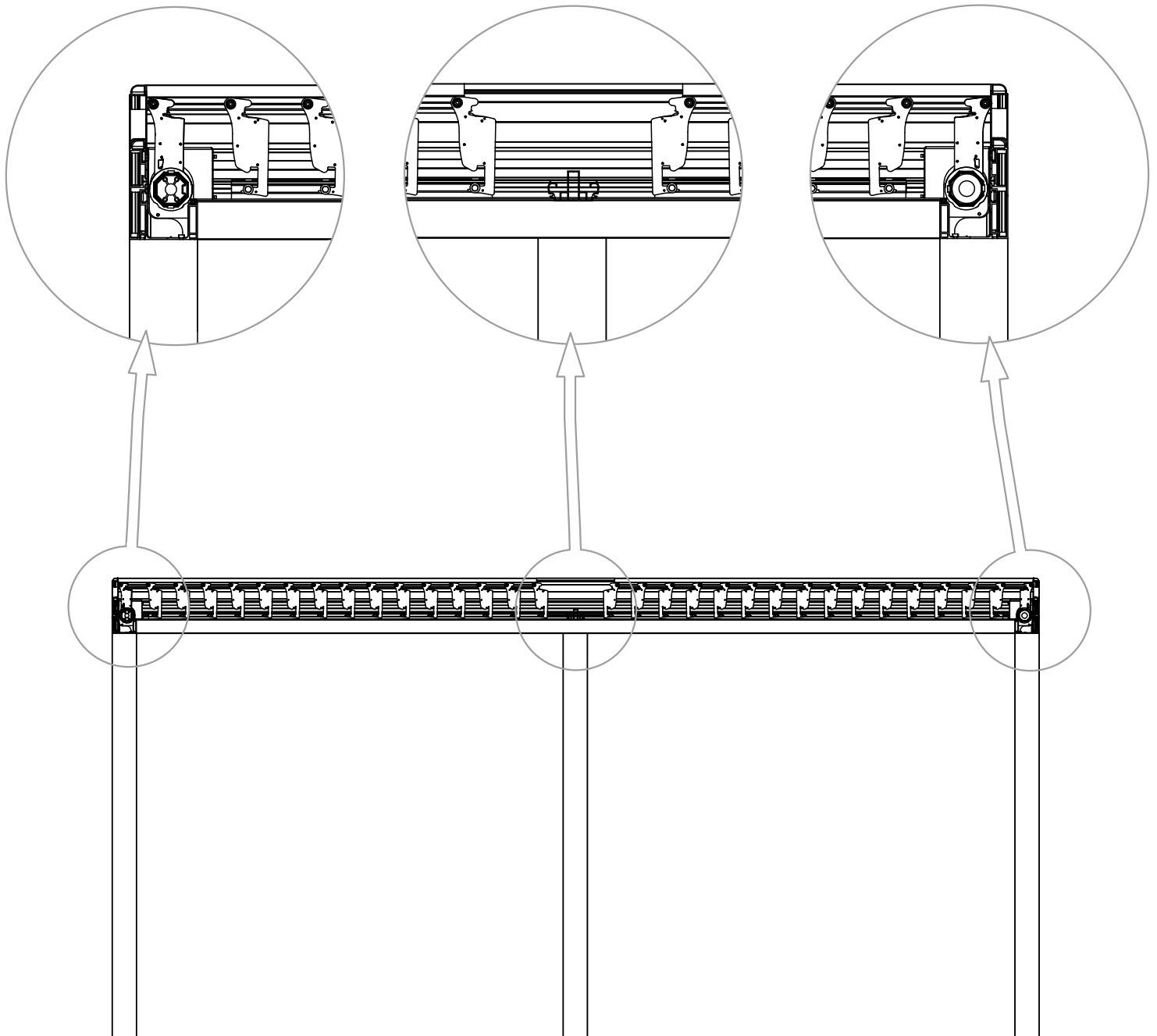

# PR6000<sup>®</sup> Lite



# PR6000® Light system diagram and list of parts Standalone

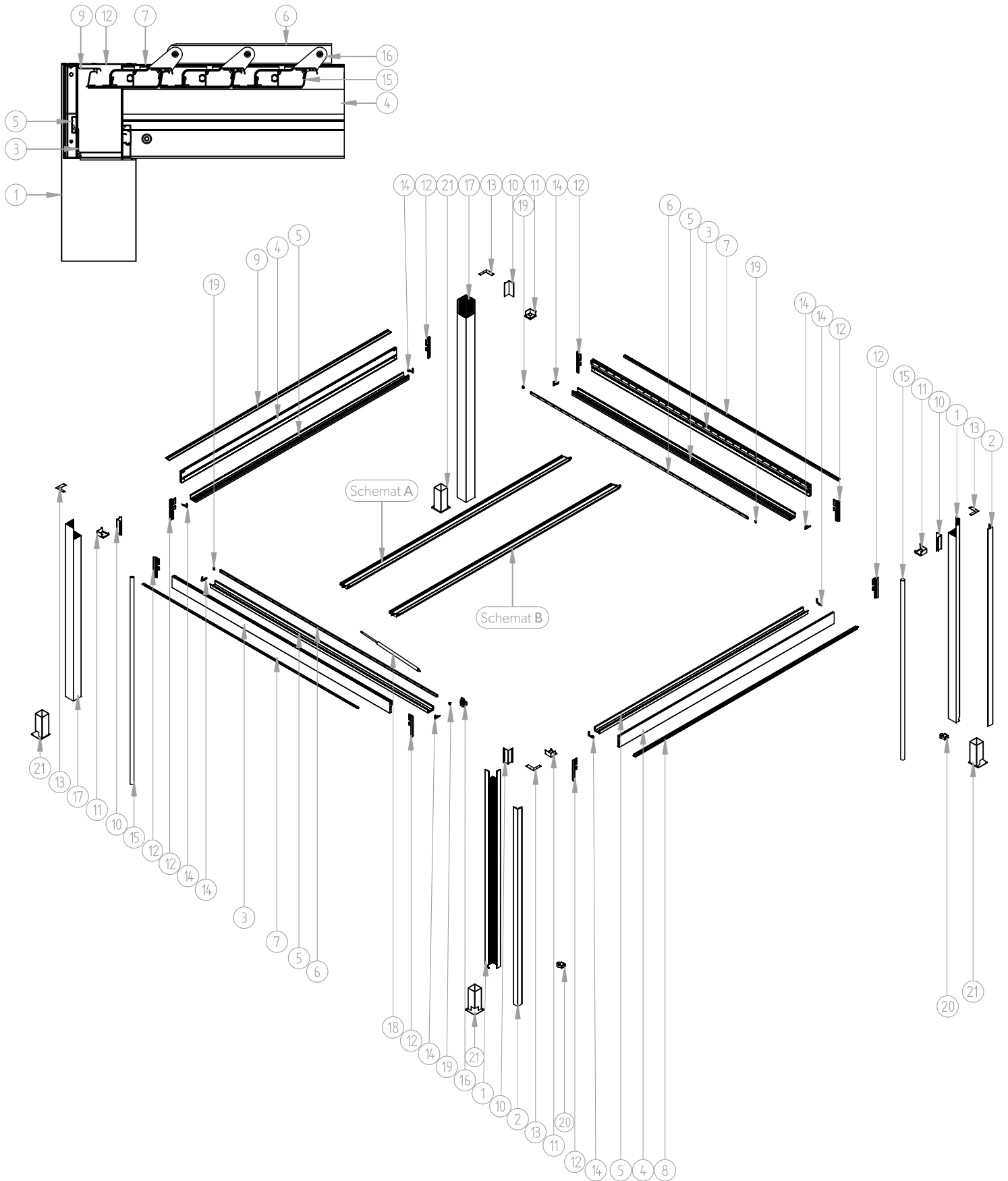

## PR6000® LITE Standalone - list of parts

1.	PWP-071 5,5M T-E	Load bearing column
2.	PWP-080	External casing of the column
3.	PWP-030	Side frame – outreach
	PWP-030 S	Side frame – Motor outreach
	PWP-031 S	Side frame – Motor outreach
4.	PWP-020	Side frame width
5.	PWP-010	Gutter bottom profile
6.	PWP-091	Slat bracket profile
7.	PWP-170	Upper end cap
8.	PWP-050	The first fixed slat
9.	PWP-040	The last fixed slat
10.	PWP-140	Corner bracket connector
11.	PWU-010	Corner seal
12.	PWP-130	Right/left corner bracket
13.	PWT-040	Upper end cap of the column
14.	PWD-070	Bottom end cap of the gutter – width
	PWD -080	Bottom end cap of the gutter – outreach – left/right
15.		Water discharge pipe
16.	PWP-160	Mounting bracket to fix the motor to the gutter
17.	PWP-180	Load bearing column without revision
18.	S-JCA-190	Motor
19.	PWD-110 L/P	Cap of the slat bracket profile
20.	PWD-100	Water outlet at the bottom of Load bearing column
21.	PWT-110	Load bearing column coupler

## PR6000® Lite system diagram and list of parts Diagram A

Diagram A - assembly drawing and list of parts of the first slat.

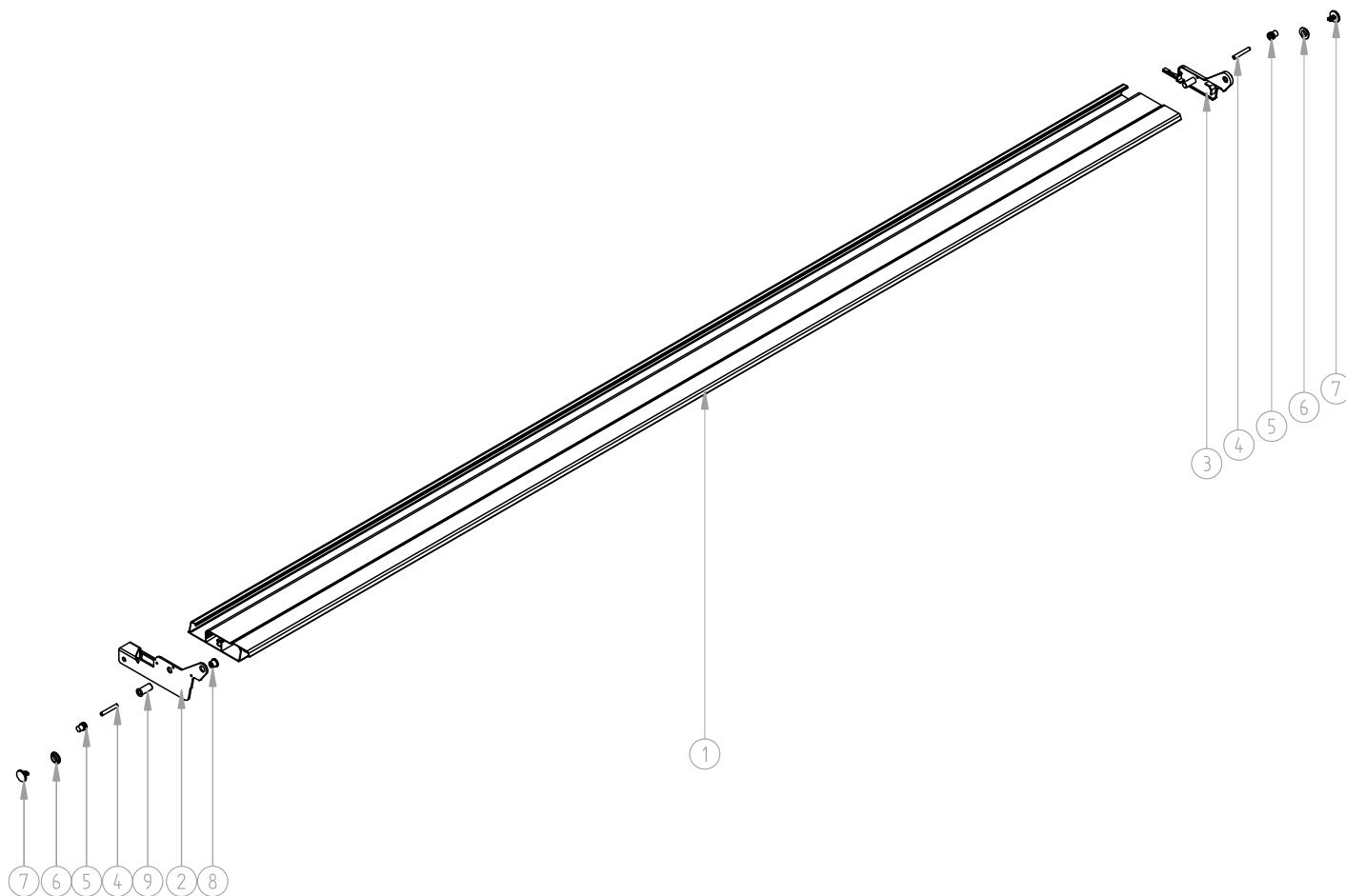

1.	PWP-060	Roof slat
2.	PWT-120	Bracket to connect slats to the motor
3.	PWD-010 L/P	Left/right side end cap of the slat
4.	PWT-010	Roll shaft 6 mm
5.	PWD-020	Slat mandrel
6.	PWD-050	Sleeve 12 mm
7.	PWD-060	Slat clamping system
8.	PWD-040	Ratchet Sleeve 12 mm for slats with a motor
9.	PWD-030	Sleeve for fastening driven lamella

Diagram B - assembly drawing and list of parts of other slats.



1.	PWP-060	Roof slat
2.	PWD-010 L/P	Left/right side end cap of the slat
3.	PWT-010	Roll shaft 6 mm
4.	PWD-020	Slat mandrel
5.	PWD-050	Sleeve 12 mm
6.	PWD-060	Slat clamping system

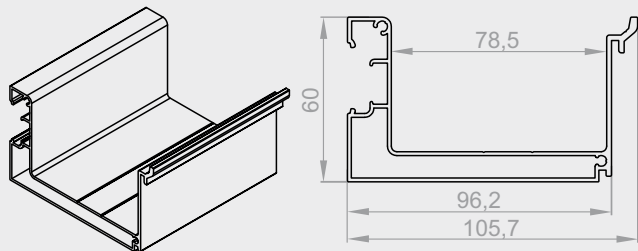

### **PWP-010**

Bottom profile – gutter.

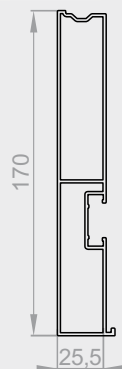
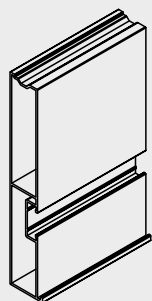

### **PWP-020**

Side frame – width.

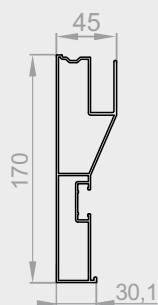
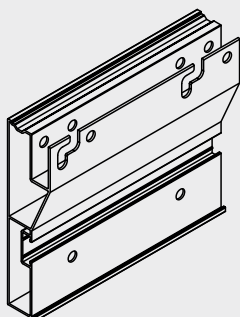

### **PWP-030**

Side frame – outreach.

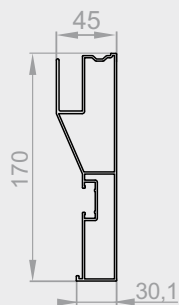
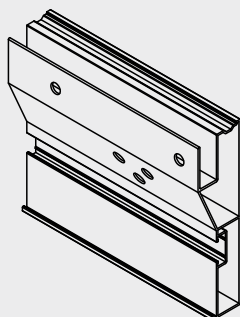

### **PWP-031 S**

Side frame – Motor outreach.



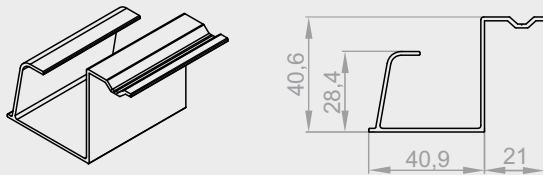
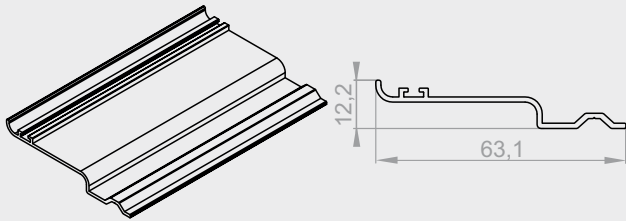

### **PWP-050**

The first fixed slat.

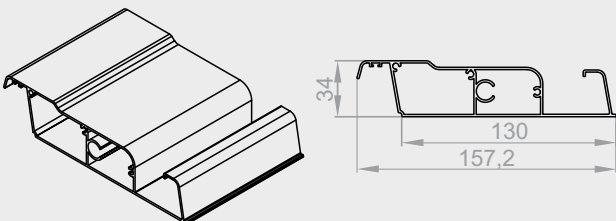

### **PWP-060**

Roof slat.

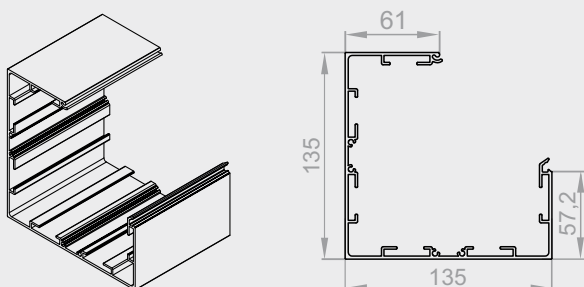

### **PWP-071 5,5M T-E**

Load bearing column.



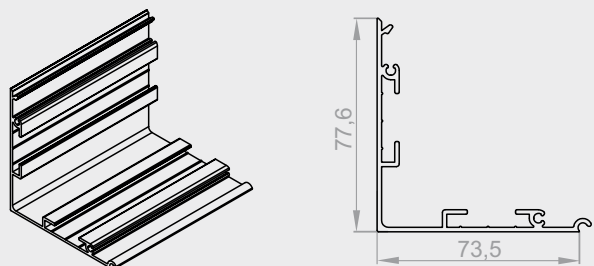

### **PWP-080**

External casing of the column.

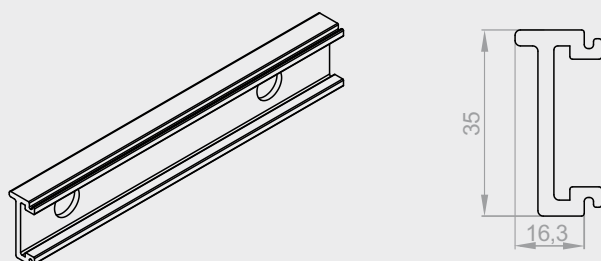

### **PWP-090**

Slat bracket profile.

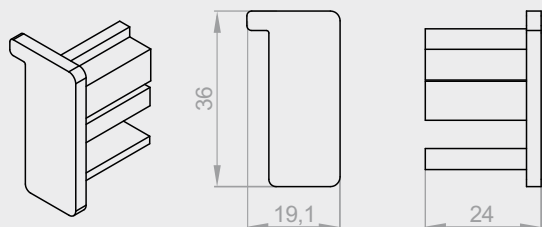

### **PWD-110 L/P**

Cap of the slat bracket profile.

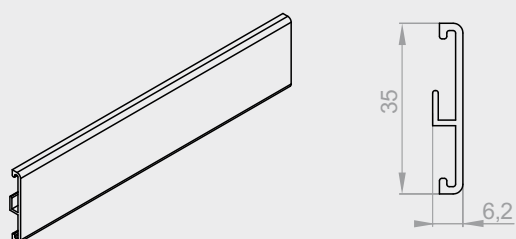

### **PWP-170**

Slat masking profile.



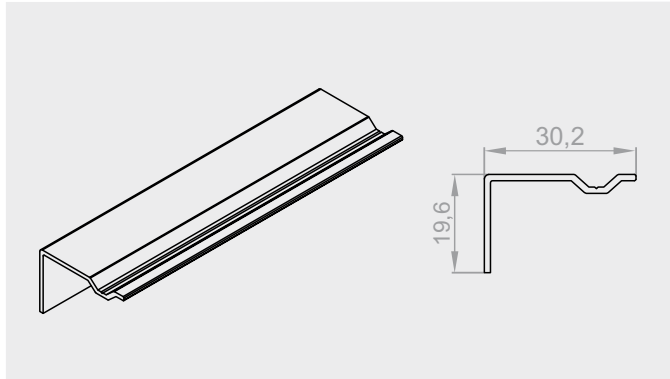

**PWP-110**

Upper end cap (outreach).

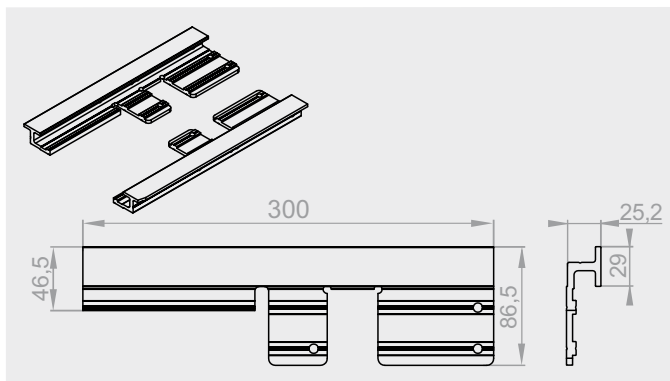

**PWP-130 L/P**

Left/right corner bracket.

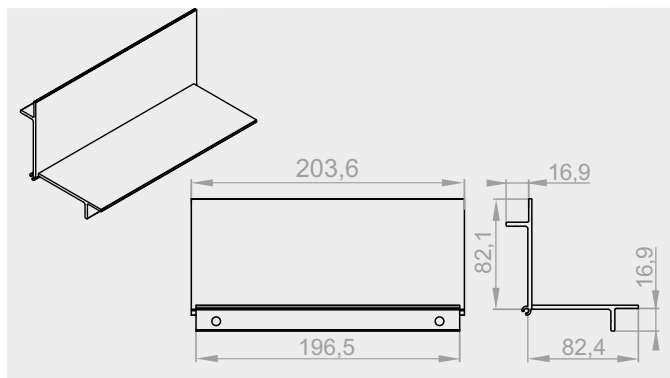

**PWP-140**

Corner bracket connector.

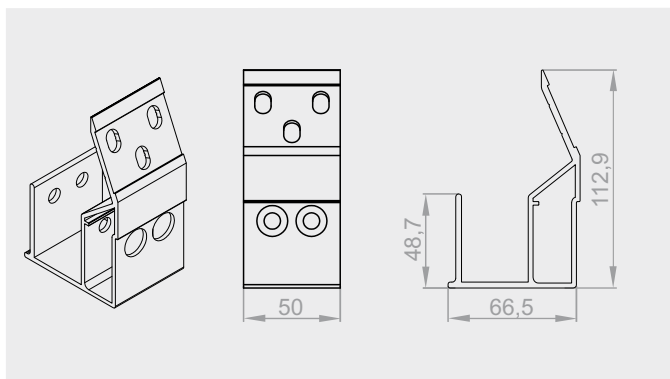

**PWP-160**

Mounting bracket to fix the motor to the gutter.



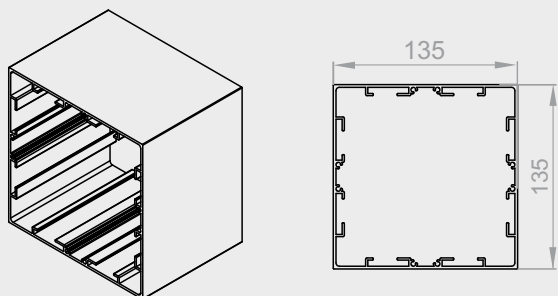

**PWP-180**

Load bearing column without revision.

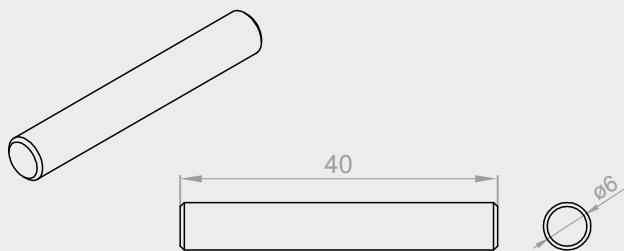

**PWT-010**

Roll shaft 6 mm.

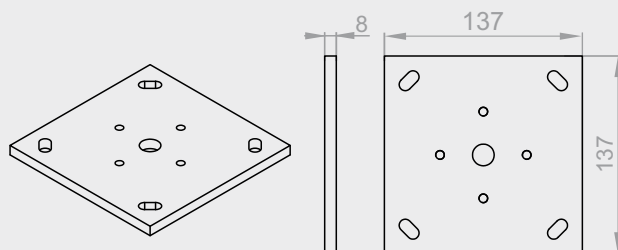

**PWT-090**

Column base bracket.

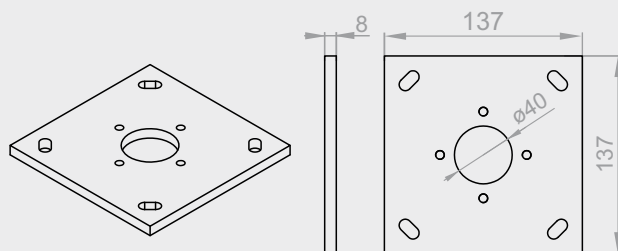

**PWT-020**

Column base bracket with 40 mm hole.



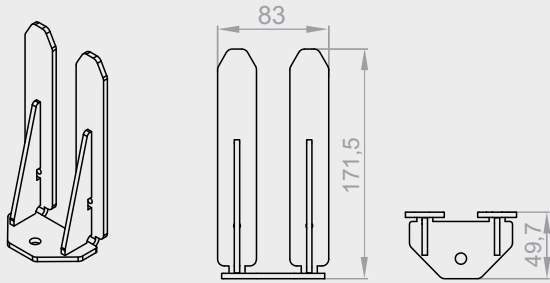

**PWT-030**

Column bracket.

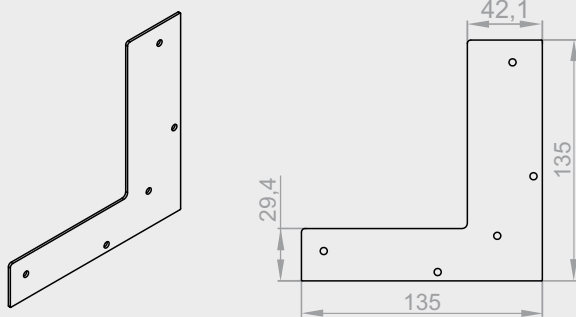

**PWT-040**

Upper end cap of the column.

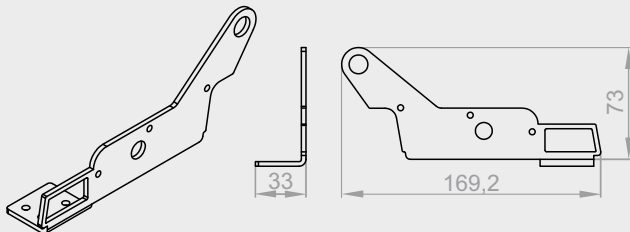

**PWT-060**

Bracket to connect slats to the motor.

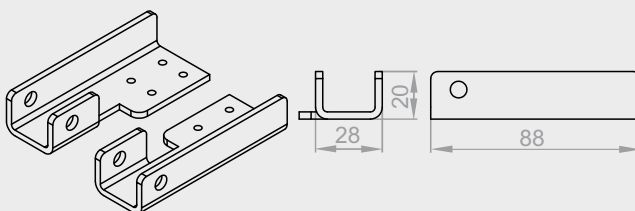

**PWT-070 L/P**

Left/right mounting bracket to fix the motor to the slats.



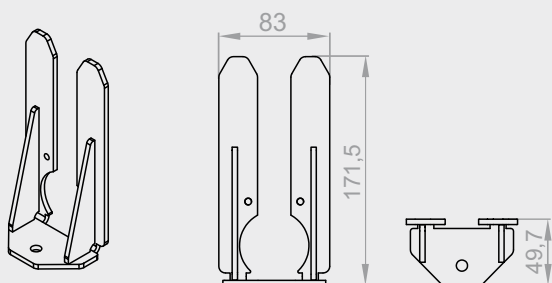

### **PWT-080**

Column bracket with a drainage hole.

STEEL

1 pc  
0,451kg

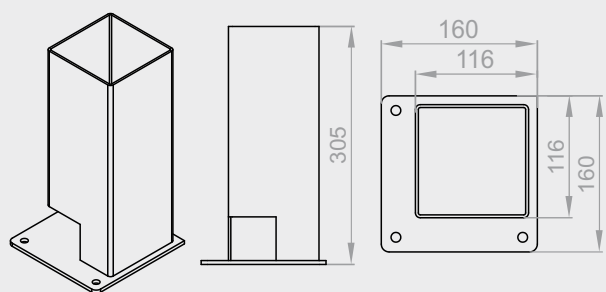

### **PWT-110**

Column bracket.

STEEL

1 pc  
3,942kg

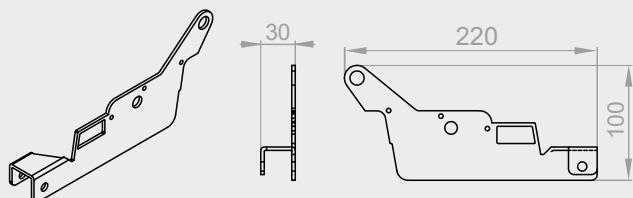

### **PWT-120**

Bracket to connect slats to the motor.

STEEL

1 pc  
0,245kg

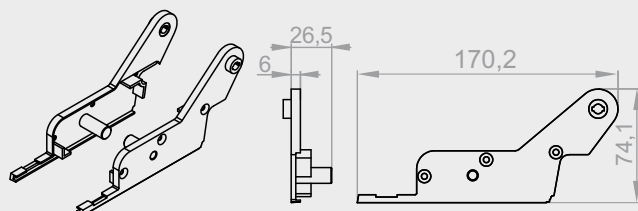

### **PWD-010 L/P**

Left/right side end cap of the slat.

PVC

1 pc  
0,02kg

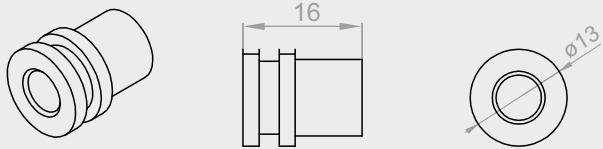

**PWD-020**  
Slat mandrel.

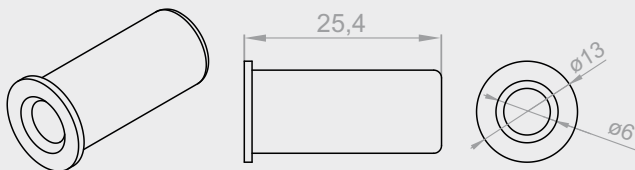

**PWD-030**  
Sleeve for fastening driven lamella.

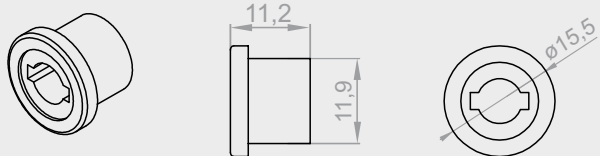

**PWD-040**  
Ratchet Sleeve 12 mm for the motor-driven slats.

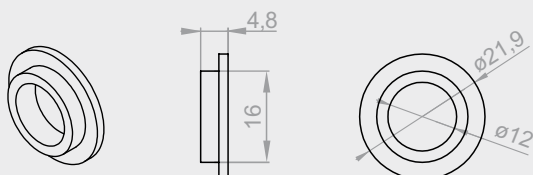

**PWD-050**  
Sleeve 12 mm.



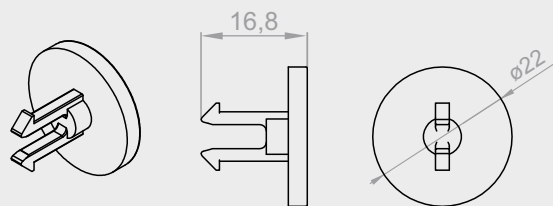

### **PWD-060**

Slat clamping system.

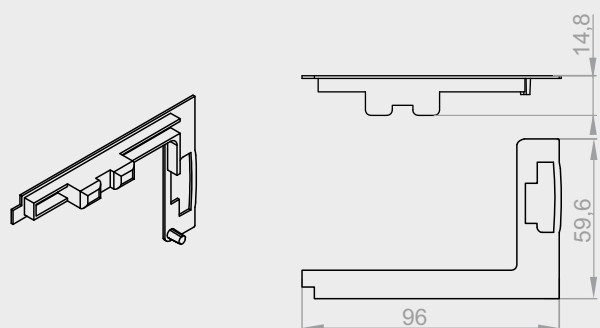

### **PWD-070**

Bottom end cap of the gutter – width.

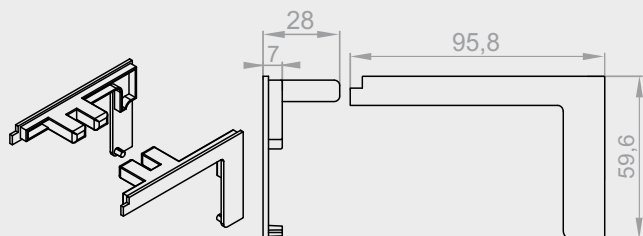

### **PWD-080 L/P**

Left/right bottom end cap of the gutter (outreach).

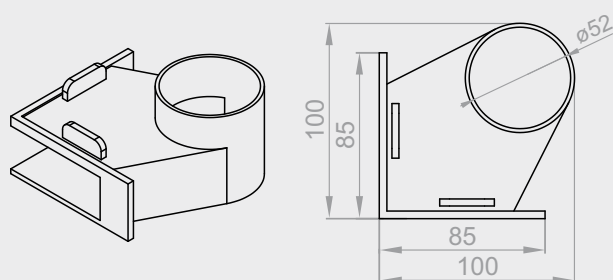

### **PWD-100**

Water outlet at the bottom of the column.



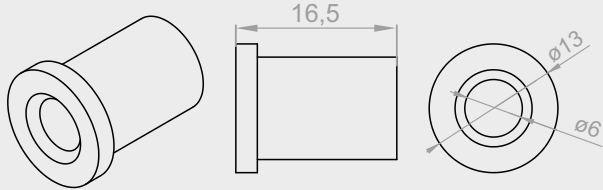

**PWD-120**  
Slat mandrel 2.

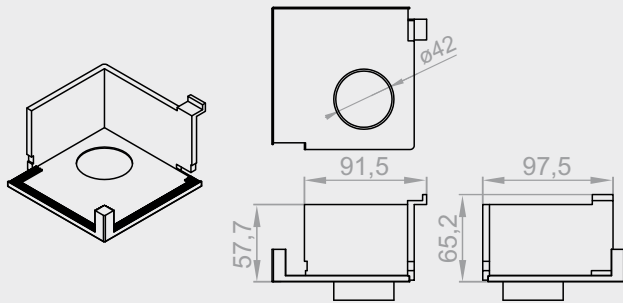

**PWU-010 L/P**  
Left/right corner seal.



## PR6000® Pergola Lite Dimensioning

Dimensioning of PR6000 pergola

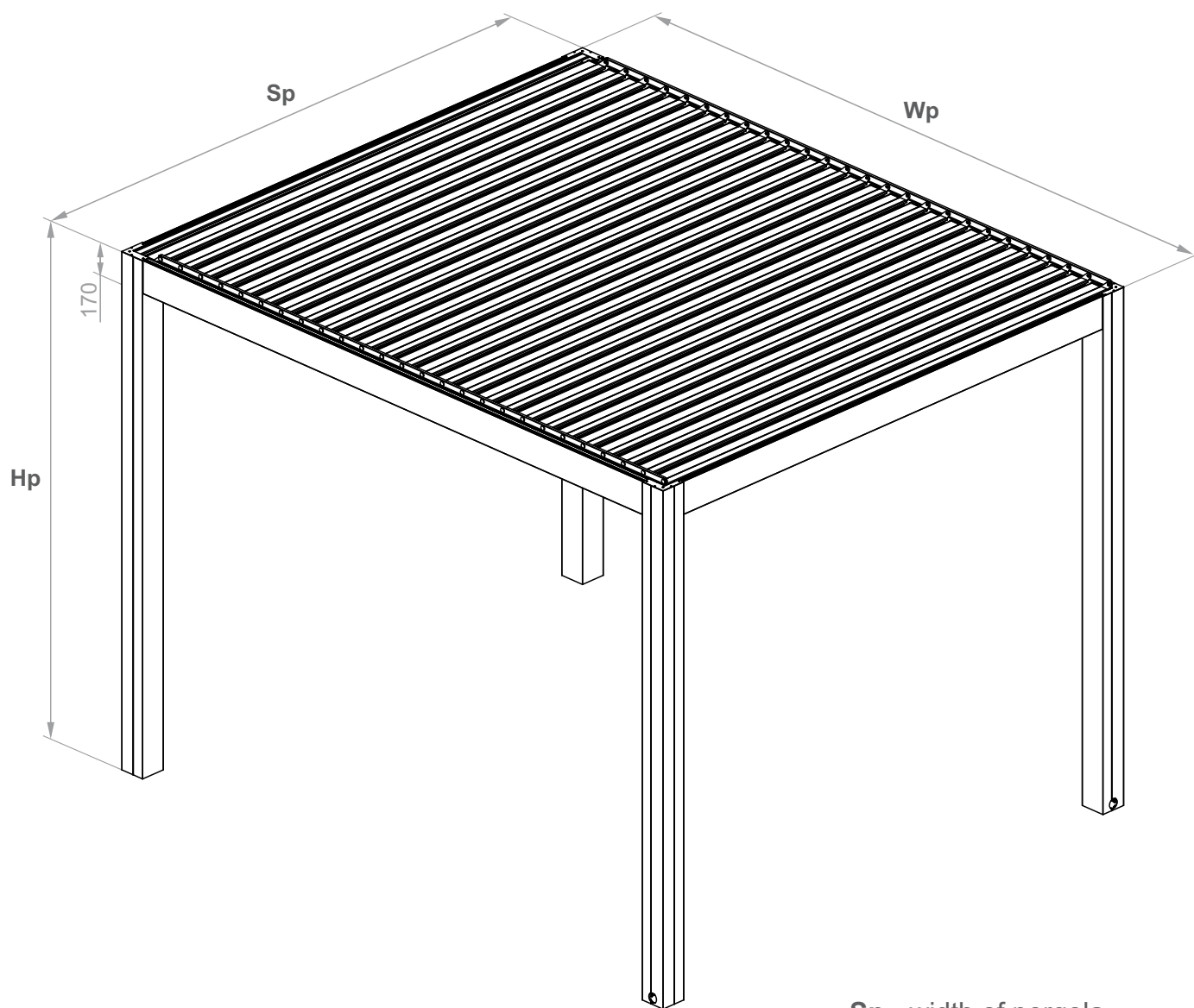

**Sp** - width of pergola  
**Wp** - outreach of pergola  
**Hp** - height of pergola



